

Pre-Engineered Systems Configurations

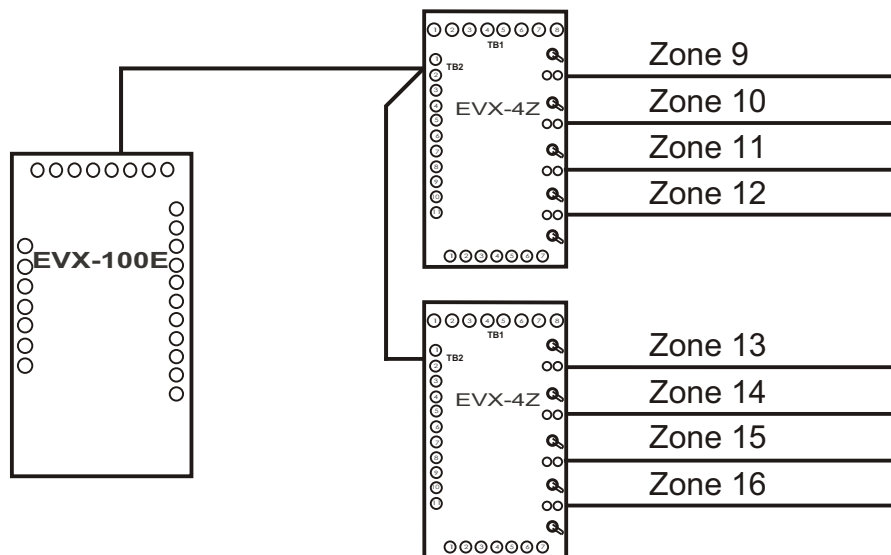
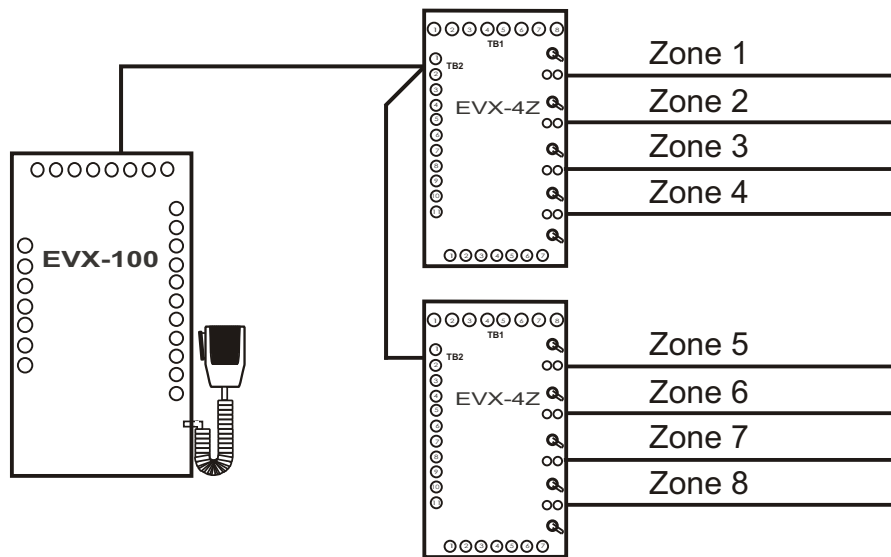

Model Number EVAX 200/16Z

Functional Block Diagrams

Maximum Load for each Evacuation Speaker Circuit is 25 Watts (15W for an EVAX 25). Never exceed the total wattage of the amplifier.