

Pre-Engineered Systems Configurations

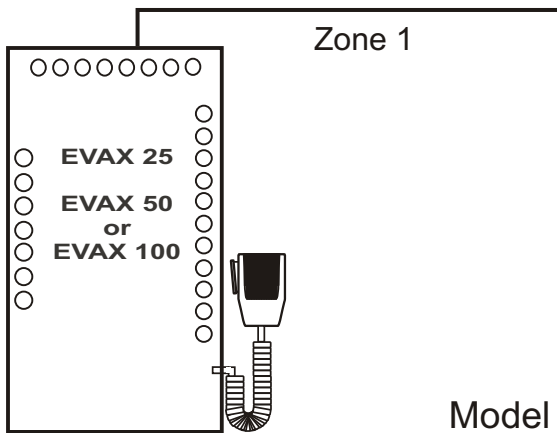

Model Number EVAX 25, EVAX 50 or EVAX 100

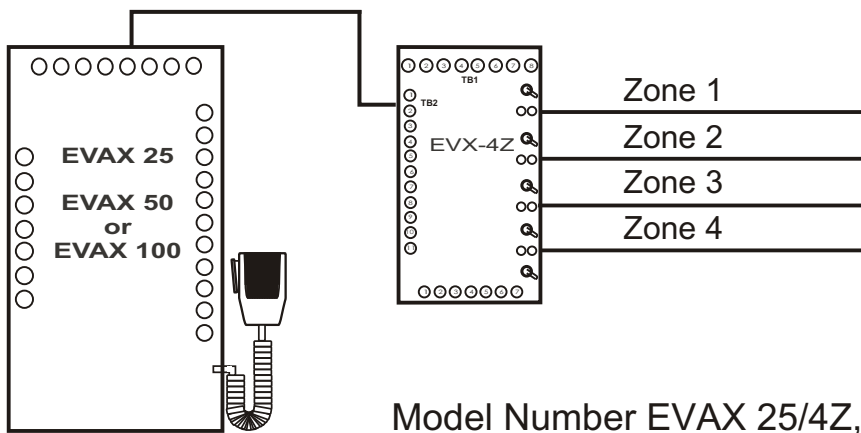

Model Number EVAX 25/4Z, EVAX 50/4Z or EVAX 100/4Z

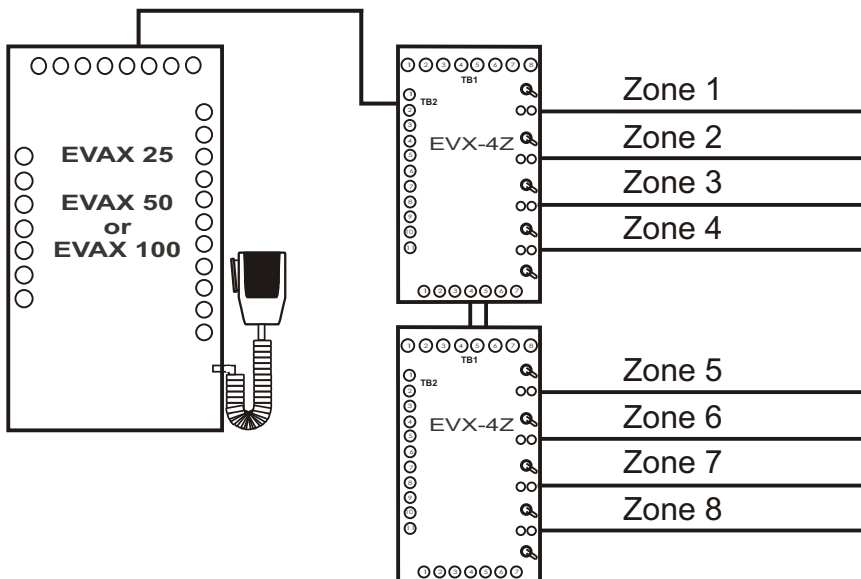

Model Number EVAX 25/8Z, EVAX 50/8Z or EVAX 100/8Z

Functional Block Diagrams

Maximum Load for each Evacuation Speaker Circuit is 25 Watts (15W for an EVAX 25). Never exceed the total wattage of the amplifier.